

## 720P AHD Colour Bumper Camera

**Model: PA 1520 IR 720P AHD**  
 High resolution, 1.3Mega Pixel, 12V DC

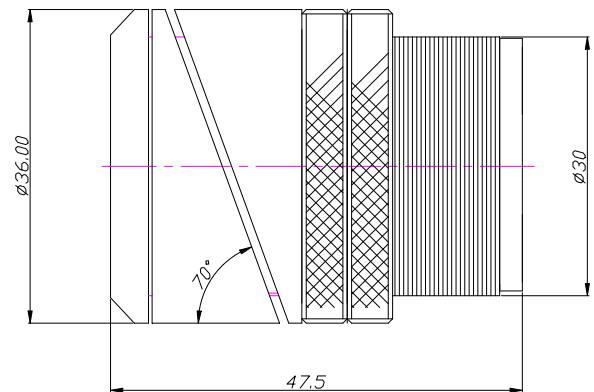

### Dimensions:



### Features:

- Metal-cased with fixed lens.
- Available in black finish.
- Low power consumption.
- IP67.
- 12 infrared LEDs.
- Option drilling tool.

### Optional drilling tool:



### Packing list:

Camera	1
Instruction Manual	1
Drilling Tool	optional

### Operation procedures:

1. Loosen the locking ring, remove the camera to the suitable position.
2. Drill 32 mm hole, Insert the camera to the bumper.
3. Fix the camera by the locking ring.
4. Connect the camera as follows.

### Connection:

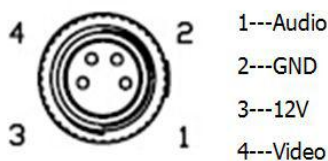

### Specifications:

Model	PA 1520 IR 720P AHD
Image Sensor	1/3" CMOS AR0130
TV System	PAL/NTSC (optional)
Picture Elements	1280 (H) x 960 (V)
Sensitivity	0 Lux (IR LED On)
Scanning System	Progressive scan RGB CMOS
Synchronization	Internal
S/N Ratio	More than 44dB (AGC Off)
Auto Gain Control (AGC)	Auto
Electronic Shutter	Auto
BLC	Auto
Infrared Spectrum	940nm
Infrared LED	12 LEDs
Video Output	1 Vp-p, 75 Ω ,AHD
Audio	N/A
Mirror	<b>Available</b>
ICR	<b>N/A</b>
Noise Reduction	3D
Dynamic range	83.5 dB
Lens	F2.8mm Megapixel
Power Supply	12V DC
Power Consumption	130mA
Dimensions (ø X H)	36 x 47.5mm
Net Weight	110g
Weatherproof	IP67
Operating Temperature	-30° C ~ +70 ° C
IR Cut	No
Connector	M12 with 60-70cm cable

*\*Specifications are subject to change without prior notice.*